

# Laser Printer

## Quick Reference

### Loading paper and specialty media

#### Loading the 250-sheet or 550-sheet tray

- 1 Pull the tray out.

**Note:** Do not remove trays while a job prints or while **Busy** appears on the display. Doing so may cause a jam.

- 2 Squeeze the width guide tab inward as shown, and move the width guide to the correct position for the paper size being loaded.

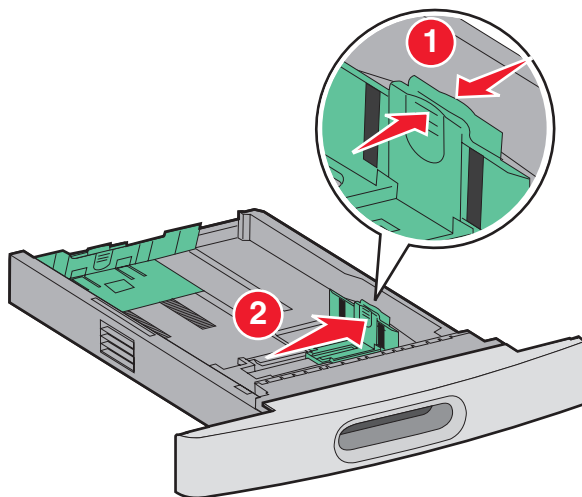

- 3 Unlock the length guide, squeeze the length guide tab inward as shown, and slide the guide to the correct position for the paper size being loaded.

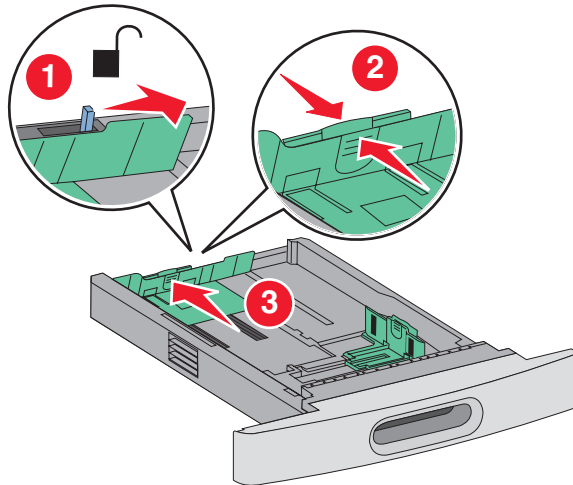

#### Notes:

- Use the size indicators on the bottom of the tray to help position the guides.
- For standard paper sizes, lock the length guide.

- 4 Flex the sheets back and forth to loosen them, and then fan them. Do not fold or crease the paper. Straighten the edges on a level surface.

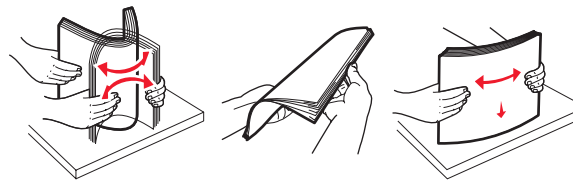

- 5 Load the paper.

- For single-sided printing, load the paper print side facedown with the leading edge of the paper toward the front of the tray.

**Note:** For print jobs using an optional StapleSmart™ II Finisher, place the leading edge of the paper toward the back of the tray.

- For two-sided or duplex printing, load the paper faceup with the leading edge of the paper toward the back of the tray.

**Note:** For print jobs using an optional StapleSmart II Finisher, place the leading edge of the paper toward the front of the tray.

**Note:** Notice the maximum fill line on the side of the tray which indicates the maximum height for loading paper. Do not overload the tray.

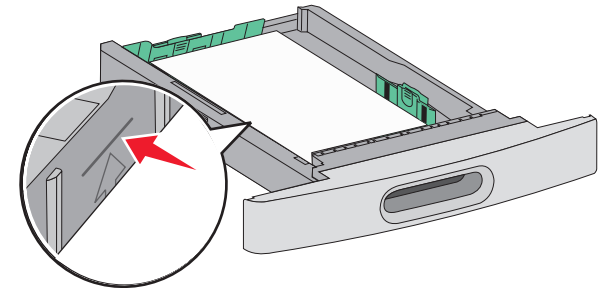

- 6 If necessary, adjust the paper guides to lightly touch the sides of the stack, and lock the length guide for the paper sizes indicated on the tray.

- 7 Insert the tray.

- 8 If a different type of paper was loaded than the type previously loaded in the tray, then change the Paper Type setting for the tray from the printer control panel.

# Clearing jams

## 200 and 201 paper jams

- 1 Push the release latch, and then lower the multipurpose feeder door.

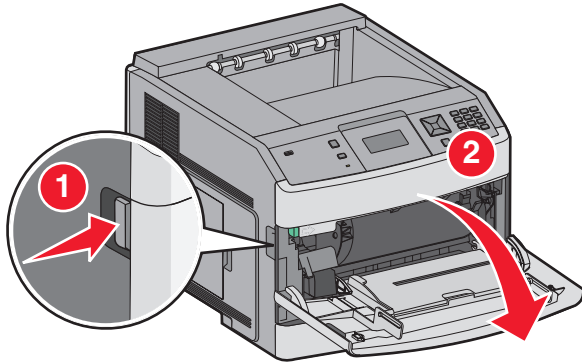

- 2 Push the release latch, and then open the front cover.

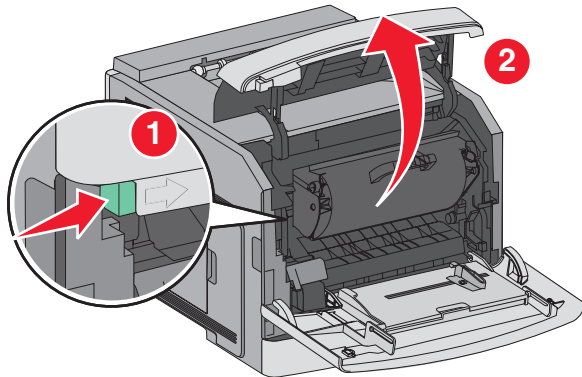

- 3 Lift and pull the print cartridge out of the printer.

**Warning—Potential Damage:** Do not touch the photoconductor drum on the underside of the cartridge. Use the cartridge handle whenever you are holding the cartridge.

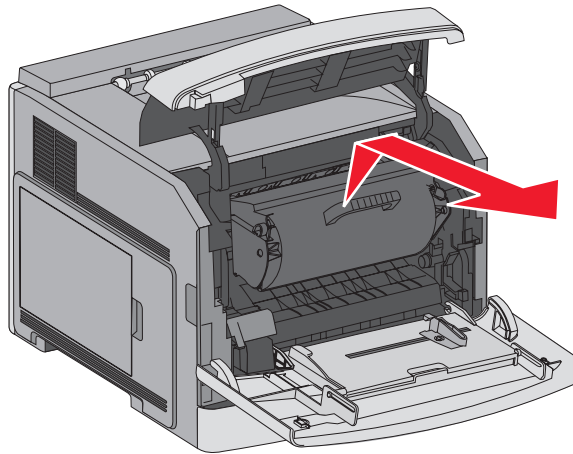

- 4 Place the print cartridge aside on a flat, smooth surface.

**Warning—Potential Damage:** Do not leave the cartridge exposed to light for extended periods.

**Warning—Potential Damage:** The jammed paper may be covered with unfused toner which can stain garments and skin.

- 5 Remove the jammed paper.

**CAUTION—HOT SURFACE:** The inside of the printer might be hot. To reduce the risk of injury from a hot component, allow the surface to cool before touching.

**Note:** If the paper is not easy to remove, then open the rear door and remove the paper from there.

- 6 Align and reinstall the print cartridge.
- 7 Close the front cover.
- 8 Close the multipurpose feeder door.
- 9 Press .

## 202 and 203 paper jams

If the paper is exiting the printer, then pull the paper out, and then press .

If the paper is not exiting the printer:

- 1 Pull down the top rear door.

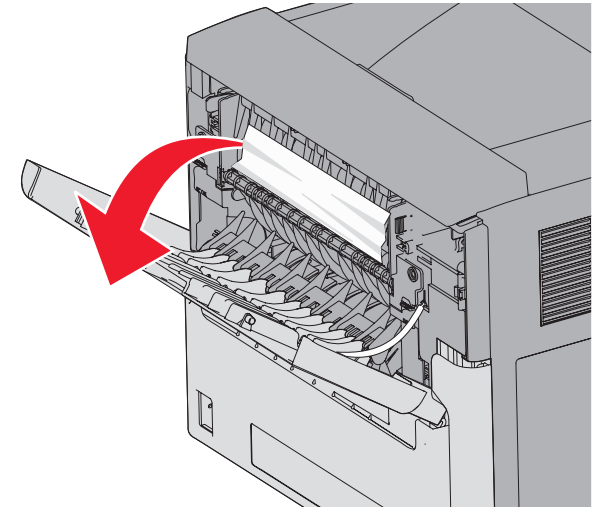

- 2 Slowly remove the jammed paper to avoid tearing it.
- 3 Close the top rear door.
- 4 Press .

## 241–245 paper jams

- 1 Pull out the tray indicated on the display.
- 2 Remove any jammed paper, and then insert the tray.
- 3 Press .
- 4 If the jam message persists for a 250- or 550-sheet tray, then remove the tray from the printer.
- 5 Remove the jammed paper, and then insert the tray.
- 6 Press .